

Hycor[®] Rotostrainer[®]

Automatic Wedgewire Fine Screen

Externally-fed, Self-cleaning Drum Screen

- Screen opening from 0.01" - 0.10" (0.25mm - 2.5mm)
- Single unit capacity up to 7800gpm (1771 m³/H)
- Widely used in municipalities and food processing companies
- Low maintenance
- Thousands of installations

Externally-fed automatic rotary wedgewire screen

Introduced over 30 years ago, the Rotostrainer® screen is the original self-cleaning wedgewire screen

The Rotostrainer® screen handles difficult solids, including scum, oily and greasy materials in municipal and industrial applications. Opening sizes are available from 0.010" (.254 mm) to 0.100" (2.54 mm). Capacities range from 60 GPM (13.6 M3/H) to 7800 GPM (1771 M3/H) in a single unit. Additional models are available to handle higher capacities.

The Rotostrainer® screen features a heavy-duty corrosion-resistant stainless steel chassis and wedgewire screening cylinder. Incoming flow is directed under a baffle to dampen forward velocity and insure even loading over the length of the screen cylinder. The natural action of wastewater cascading through the screen creates a powerful backwash which results in a continuously clean surface. Solids are caught on the outside of the screen surface and are removed by a tensioned doctor blade.

All Rotostrainer® units have an internal spray bar available. This spray bar is positioned within inches of the surface of the cylinder and benefits greasy applications or applications requiring small size screen openings.

The Hycor® Rotostrainer® screen is the only rotary screen available with an automatic doctor blade cleaner assembly that wipes away solids, particularly sticky materials that build up on the primary doctor blade.

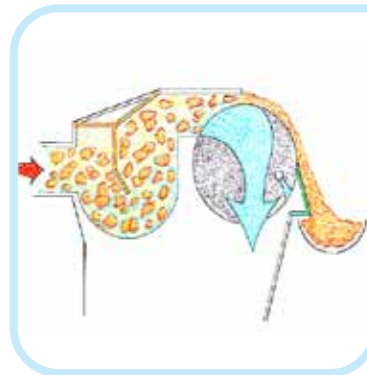
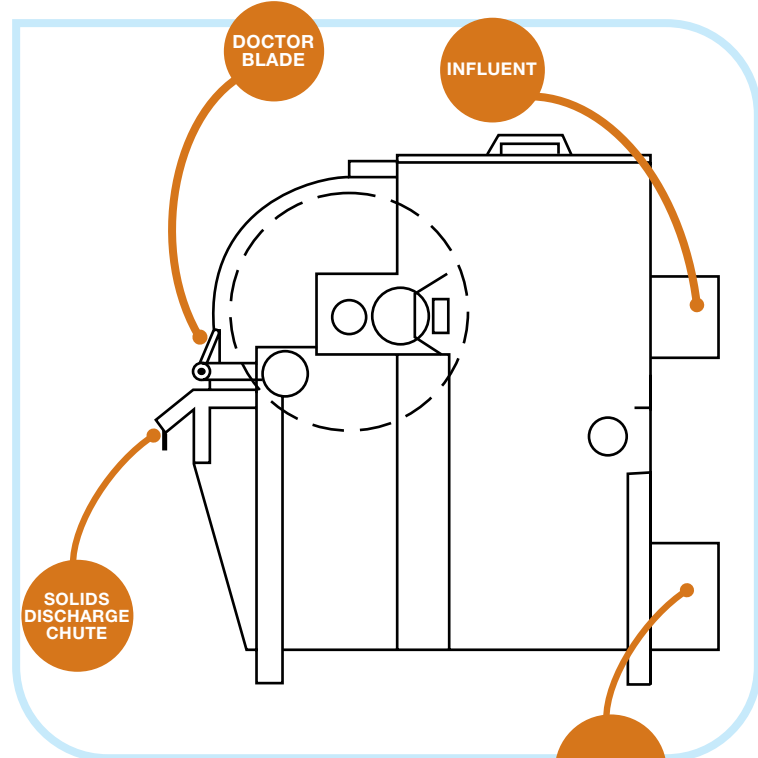



Screens discrete solids, scum and oily materials without blinding

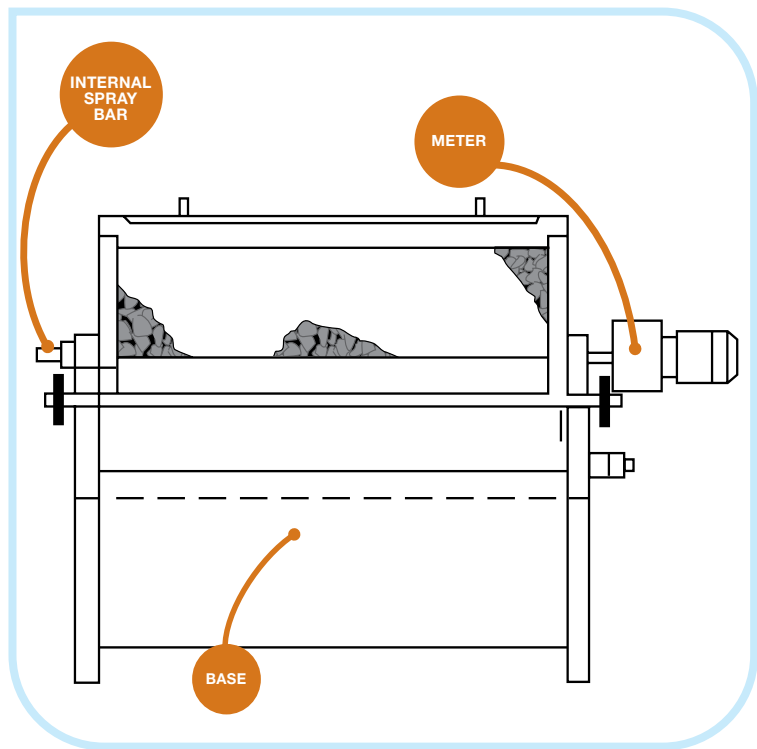
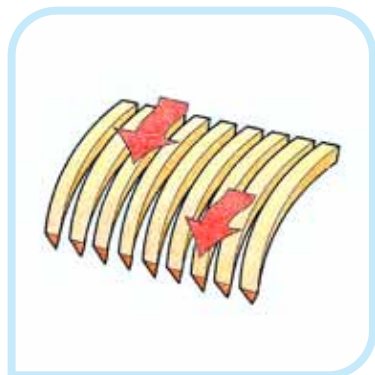

Features

- Horizontally mounted cylinder has external bearings to simplify maintenance
- Adjustable counter-weighted primary doctor blade without a spring tensioning mechanism minimizes accidental over-tensioning
- Removable headbox cover minimizes splashing and reduces housekeeping
- Easily accessible headbox simplifies routine maintenance
- Optional base is an integral part of the chassis and requires no sealing or gasketing
- Simplified motor arm brackets reduce stress and fatigue
- Corrosion-resistant stainless steel construction
- Automatic doctor blade cleaner to facilitate solids removal from primary blade
- Optional 100% bypass
- Thousands of units sold

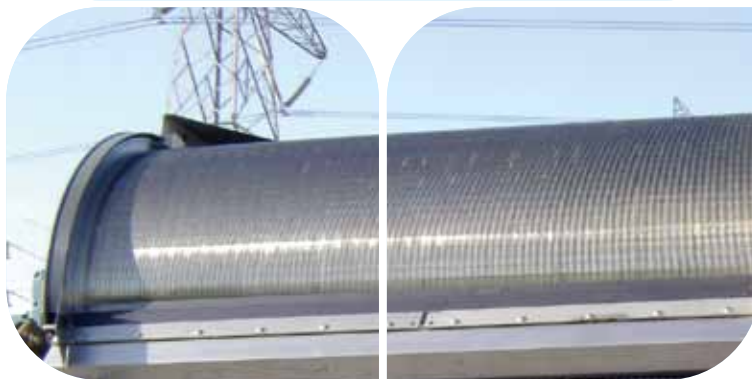

Multiple units feeding conveyor



Automatic doctor blade cleaner



Rotostrainer® Screens – Superior by Design

In food processing and wastewater, FOGs cause blinding, which many screens have a hard time dealing with. With Parkson's Rotostrainer® screens you can rest assured that all scum, and oily materials will be handled effectively.

With thousands of installations and 30 years experience, the Rotostrainer® has been the choice of many municipalities and industries.



Comparative table

Model No.	Motor HP	Screen Dia	Screen Length	Height			
				Dry Wt.		Operating Wt.	
				w/ base	w/o base	w/ base	w/o base
2512	1/3 (.25)	25 (626)	12 (305)	600 (272)	490 (222)	1016 (460)	607 (275)
2524	1/3 (.25)	25 (626)	24 (610)	716 (325)	581 (263)	1548 (702)	815 (370)
2548	1/2 (.38)	25 (626)	48 (1220)	989 (449)	805 (365)	2653 (1203)	1273 (577)
2572	1/2 (.38)	25 (626)	72 (1829)	1297 (589)	1064 (482)	3793 (1722)	1766 (801)
2584	1/2 (.38)	25 (626)	84 (2134)	1430 (649)	1172 (532)	4342 (1971)	1991 (904)
3672	3/4 (.55)	36 (915)	72 (1829)	1850 (840)	1650 (749)	6450 (2926)	3250 (1474)
3684	3/4 (.55)	36 (915)	84 (2134)	2150 (975)	1925 (873)	7000 (3175)	3795 (1721)
36120	1 (.75)	36 (915)	117 1/2 (2985)	2940 (1334)	2650 (1202)	8450 (3833)	5250 (2381)



Fort Lauderdale
Chicago
Montreal
Dubai
Mumbai

1.888.PARKSON
technology@parkson.com
www.parkson.com